

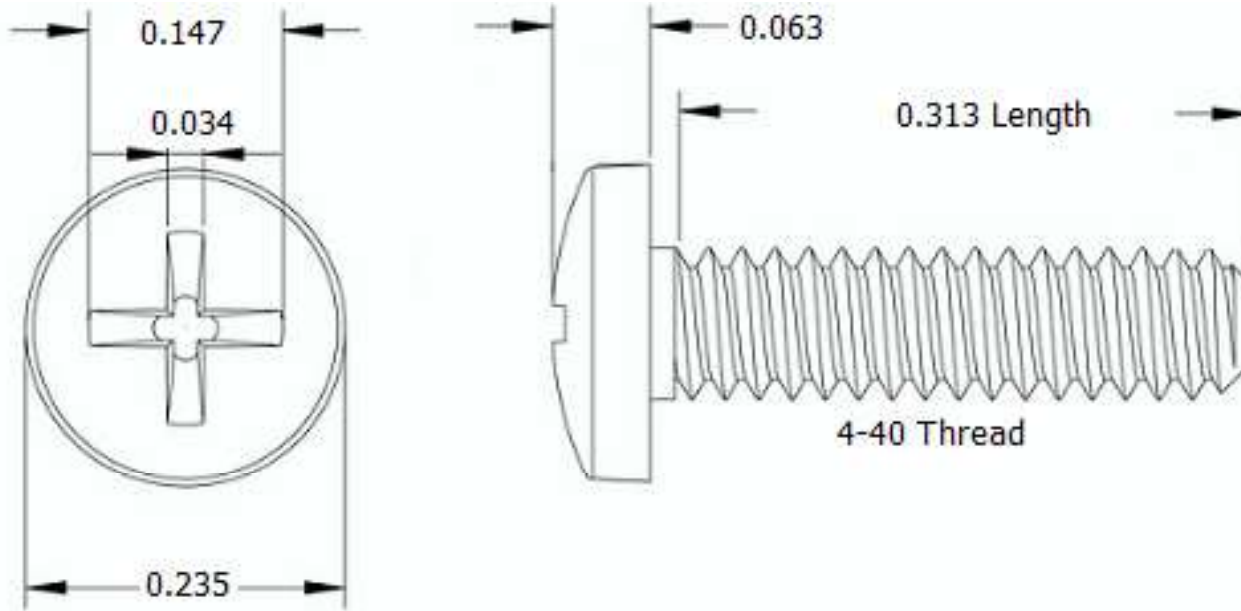

This drawing and the information contained herein are the confidential and proprietary property of Global Supply LLC



NOTES:

1. INTERPRET DRAWINGS PER ASME Y14.5M-1994 STANDARD.
2. DIMENSIONS & TOLERANCES PER ANSI/ASME B18.6.3
3. ROHS AND REACH COMPLIANT

DRAWING SCALE:		MATERIAL:	DESCRIPTION:						
STANDARD		NYLON	4-40 X 5/16 PHILLIPS BINDER HEAD MACHINE SCREW						
TOLERANCES: <i>Unless specified otherwise, all dimensions are in inches</i>	<table border="0"> <tr><td>x.xxx</td><td>+/- 0.005</td></tr> <tr><td>x.xx</td><td>+/- 0.010</td></tr> <tr><td>x.x</td><td>+/- 0.010</td></tr> </table>	x.xxx	+/- 0.005	x.xx	+/- 0.010	x.x	+/- 0.010	FINISH:	PART NUMBER:
x.xxx	+/- 0.005								
x.xx	+/- 0.010								
x.x	+/- 0.010								
		PLAIN	010440WB031						
DRAWN BY:	L. CLARY		 <p>Global Supply LLC WORLDWIDE SUPPLIER OF ELECTRONIC HARDWARE, FASTENERS & COMPONENTS 500 Division Street, Campbell, CA 95008-6906 Tel: 408 960 0370 Fax: 408 960 0375 Web: www.globalsupply.com</p>						
REV:	APPROVAL	DATE:							
INITIAL REV	LJA	Jul 6, 2018							
		FCSM No. 67012							
		ECCN							
		EAR99 = NLR (No License Required)							