

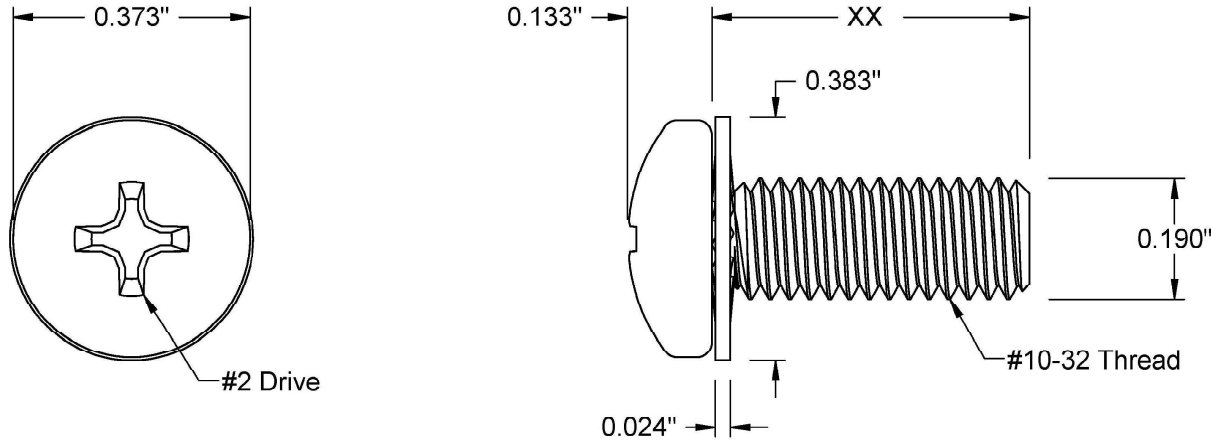

This drawing and the information contained herein are the confidential and proprietary property of Global Supply LLC



PART NUMBER	LENGTH
10F8MPPSP/SIN	1/8
10F12MPPSP/SIN	3/16
10F16MPPSP/SIN	1/4
10F20MPPSP/SIN	5/16
10F24MPPSP/SIN	3/8
10F28MPPSP/SIN	7/16
10F32MPPSP/SIN	1/2
10F40MPPSP/SIN	5/8
10F48MPPSP/SIN	3/4
10F56MPPSP/SIN	7/8
10F64MPPSP/SIN	1
10F80MPPSP/SIN	1 1/4
10F96MPPSP/SIN	1 1/2

NOTES:  
 1. INTERPRET DRAWINGS PER ASME Y14.5M-1994 STANDARD.  
 2. DIMENSIONS & TOLERANCES PER ANSI/ASME B18.6.3  
 3. ROHS AND REACH COMPLIANT

<b>DRAWING SCALE:</b> <b>STANDARD</b>		<b>MATERIAL:</b> <b>STAINLESS STEEL</b>	<b>DESCRIPTION:</b> <b>#10-32 PAN PHILLIPS MACHINE SCREW, SEMS INTERNAL</b>
<b>TOLERANCES:</b> <i>Unless specified otherwise, all dimensions are in inches</i>	x.xxx +/- 0.005 x.xx +/- 0.010 x.x +/- 0.010	<b>FINISH:</b> <b>PASSIVATE</b>	<b>PART NUMBER:</b> <b>10FXXMPPSP/SIN</b>
<b>DRAWN BY:</b> L.CLARY	<b>FSCM No.</b> <b>67012</b>		 <b>Global Supply LLC</b> WORLDWIDE SUPPLIER OF ELECTRONIC HARDWARE, FASTENERS & COMPONENTS <small>500 Division Street, Campbell, CA 95008-6906          Tel: 408 960 0370 Fax: 408 960 0375 Web: www.globalsupply.com</small>
<b>REV:</b>	<b>APPROVAL</b>	<b>DATE:</b>	
INITIAL RELEASE	LJA	Sep 3, 2009	
A	LJA	Sep 26, 2014	
B	LJA	Mar 15, 2018	<b>ECCN</b> EAR99 = NLR (No License Required)