

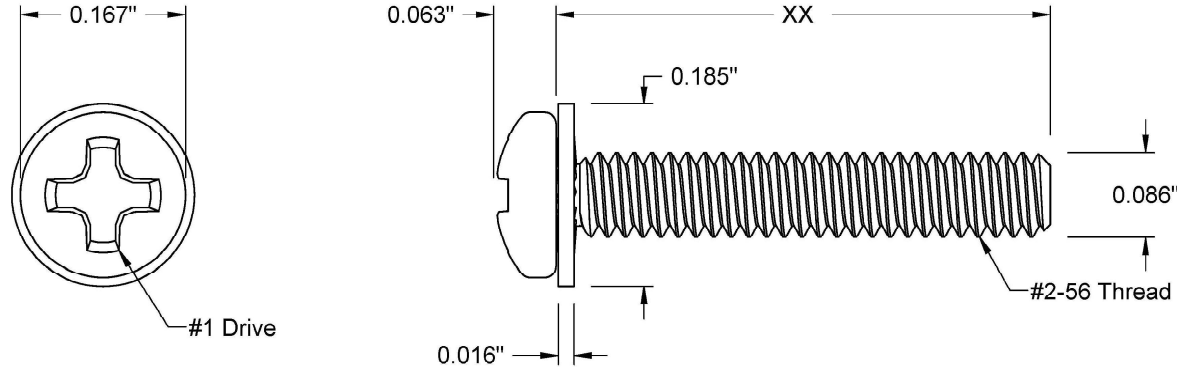

This drawing and the information contained herein are the confidential and proprietary property of Global Supply LLC



PART NUMBER	LENGTH
2C8MPPSP/SSQ	1/8
2C12MPPSP/SSQ	3/16
2C16MPPSP/SSQ	1/4
2C20MPPSP/SSQ	5/16
2C24MPPSP/SSQ	3/8
2C28MPPSP/SSQ	7/8
2C32MPPSP/SSQ	1/2
2C36MPPSP/SSQ	9/16
2C40MPPSP/SSQ	5/8
2C48MPPSP/SSQ	3/4
2C56MPPSP/SSQ	7/8
2C64MPPSP/SSQ	1

NOTES:
 1. INTERPRET DRAWINGS PER ASME Y14.5M-1994 STANDARD.
 2. DIMENSIONS & TOLERANCES PER ANSI/ASME B18.6.3
 3. ROHS AND REACH COMPLIANT

DRAWING SCALE:		MATERIAL:	DESCRIPTION:
STANDARD		STAINLESS STEEL	#2-56 PAN PHILLIPS HEAD M/S, SQUARE CONE SEMS
TOLERANCES: <i>Unless specified otherwise, all dimensions are in inches</i>	x.xxx +/- 0.005 x.xx +/- 0.010 x.x +/- 0.010	FINISH:	PART NUMBER:
DRAWN BY:	L.CLARY	PASSIVATE	2CXXMPPSP/SSQ
REV:	APPROVAL	FSCM No.	 Global Supply LLC WORLDWIDE SUPPLIER OF ELECTRONIC HARDWARE, FASTENERS & COMPONENTS <small>500 Division Street, Campbell, CA 95008-6906 Tel: 408 960 0370 Fax: 408 960 0375 Web: www.globalsupply.com</small>
INITIAL RELEASE	LJA	DATE:	
		Apr 11, 2018	
		ECCN	
		EAR99 = NLR (No License Required)	