

This drawing and the information contained herein are the confidential and proprietary property of Global Supply LLC

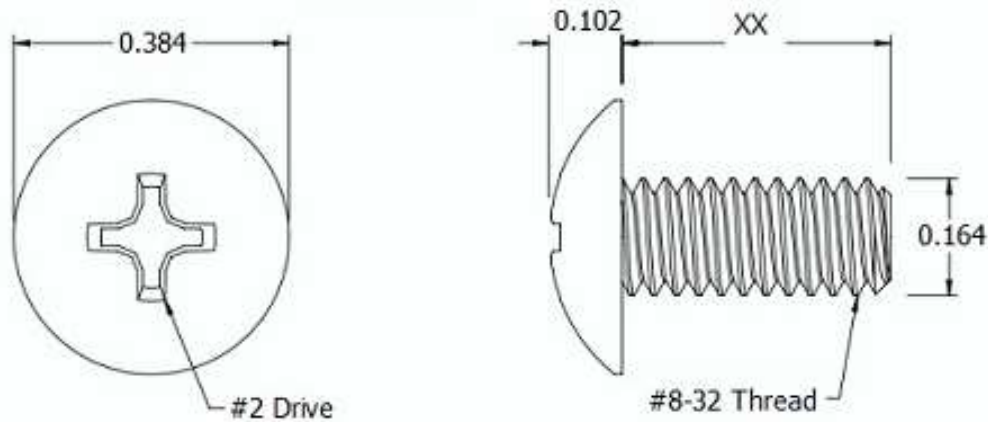

PART NUMBER	LENGTH
8C8MPT2Z	1/8
8C12MPT2Z	3/16
8C16MPT2Z	1/4
8C20MPT2Z	5/16
8C24MPT2Z	3/8
8C32MPT2Z	1/2
8C40MPT2Z	5/8
8C48MPT2Z	3/4
8C56MPT2Z	7/8
8C64MPT2Z	1



NOTES:  
 1. INTERPRET DRAWINGS PER ASME Y14.5M-1994 STANDARD.  
 2. DIMENSIONS & TOLERANCES PER ANSI/ASME B18.6.3.

<b>DRAWING SCALE:</b>		<b>MATERIAL:</b>	<b>DESCRIPTION:</b>
<b>STANDARD</b>		<b>STEEL</b>	<b>8-32 PHILLIPS TRUSS HEAD MACHINE SCREW</b>
<b>TOLERANCES:</b> <i>Unless specified otherwise, all dimensions are in inches</i>	x.xxx +/- 0.005 x.xx +/- 0.010 x.x +/- 0.010	<b>FINISH:</b>	<b>PART NUMBER:</b>
		<b>ZINC I</b>	<b>8CXXMPT2Z</b>
<b>DRAWN BY:</b>	L CLARY	<b>FSCM No.</b>	 <b>Global Supply LLC</b> WORLDWIDE SUPPLIER OF ELECTRONIC HARDWARE, FASTENERS & COMPONENTS <small>500 Division Street, Campbell, CA 95008-6906          Tel: 408 960 0370 Fax: 408 960 0375 Web: www.globalsupply.com</small>
<b>REV:</b>	<b>APPROVAL</b>	<b>DATE:</b>	
<b>INITIAL RELEASE</b>	LJA	<b>Sep 13, 2018</b>	
		<b>ECCN</b>	
		<b>EAR99 = NLR (No License Required)</b>	